

DIP SWITCH DHA SERIES

2.2mm
Half Pitch Type

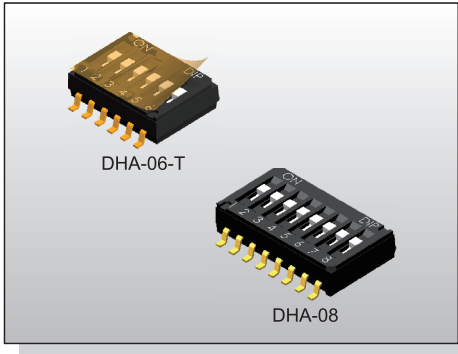

FEATURES

- ※ Low profile 2.2mm height
- ※ Gold contact for high reliability
- ※ Top tape type for washing process

APPLICATION

- ※ Industrial control
- ※ Automatic machines control
- ※ NB, electronic devices

SPECIFICATION

Contact Rating	25mA, 24V DC
Contact Resistance	100mΩ max. Initial
Insulation Resistance	100MΩ min. 500V DC
Dielectric Strength	300V AC/1 minute
Operating Force	500gf
Travel	0.8mm
Operating Life	1,000 cycles
Operating Temp.	-40°C ~ +85°C
Storage Temp.	-40°C ~ +85°C

HOW TO ORDER

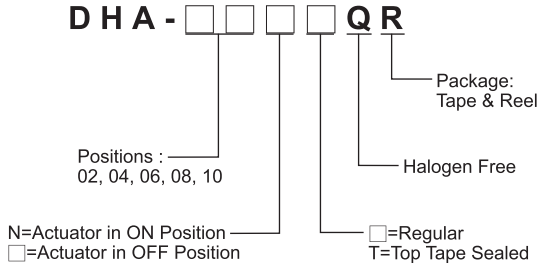

CIRCUIT

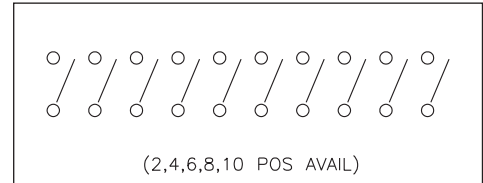

PACKAGE

<Tape & Reel>
1800 pcs

DHA

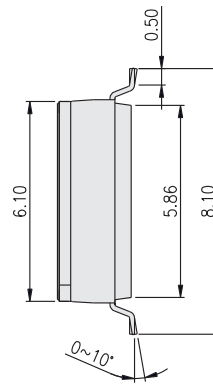
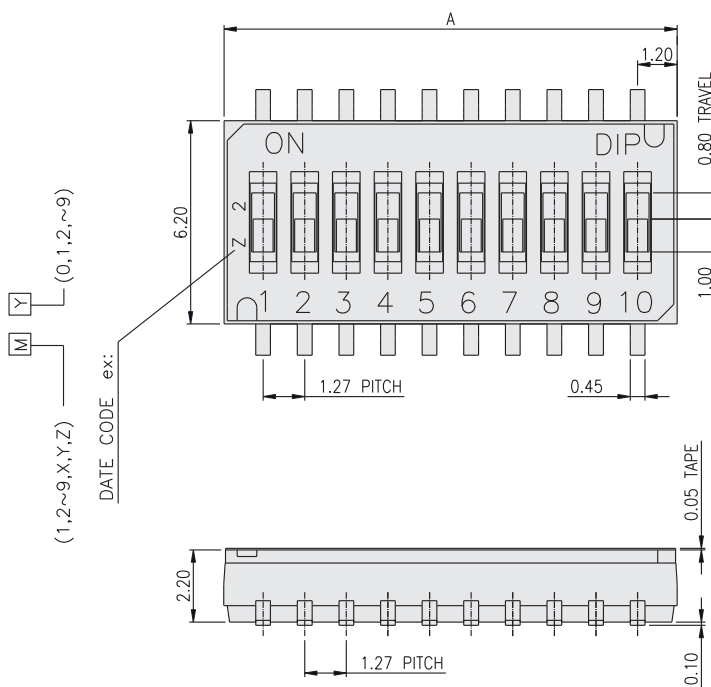

DHA-10	10	13.83
DHA-08	8	11.29
DHA-06	6	8.75
DHA-04	4	6.21
DHA-02	2	3.67
PROD.NO.	NO.OF POS	DIM A

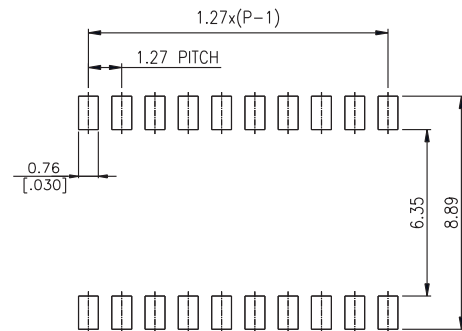

P.C.B. LAYOUT

DIP SWITCH