

**TOP VIEW**

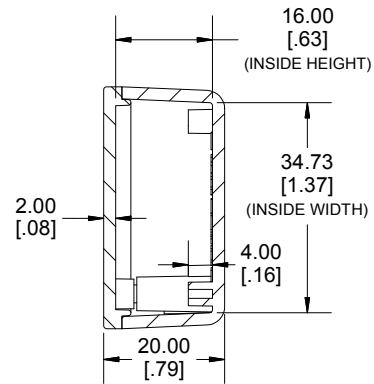

**END VIEW  
SECTION B-B**

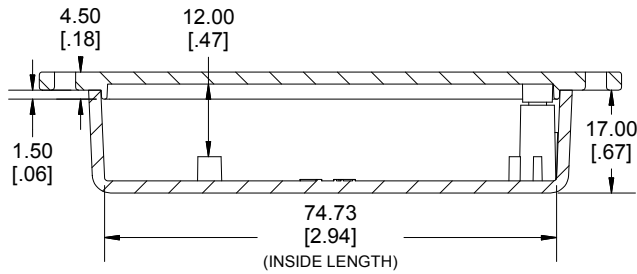
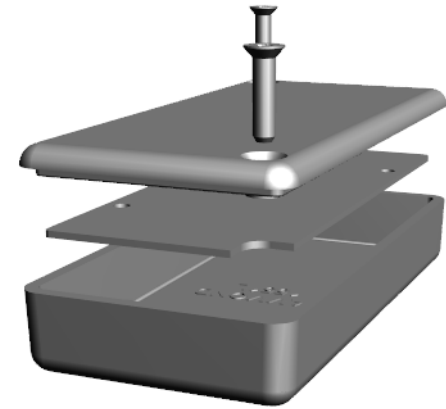

**SIDE VIEW  
SECTION A-A**

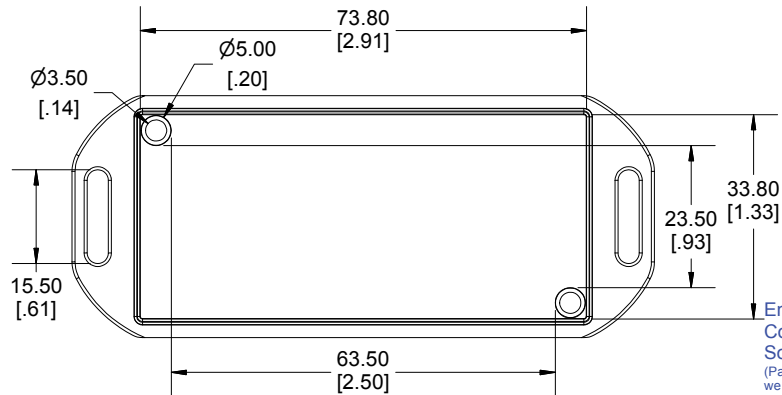

**INSIDE LID**

Enclosures can be Factory Modified ( Milling, Drilling, Printing etc.)  
 Contact Factory [mjm@hammondmfg.com](mailto:mjm@hammondmfg.com) for quotes  
 Solid models of this enclosure available in STEP or IGES.  
 (Part number and text placement/orientation on our products are subject to change,  
 we do not recommend using them as a locating reference for modification purposes)

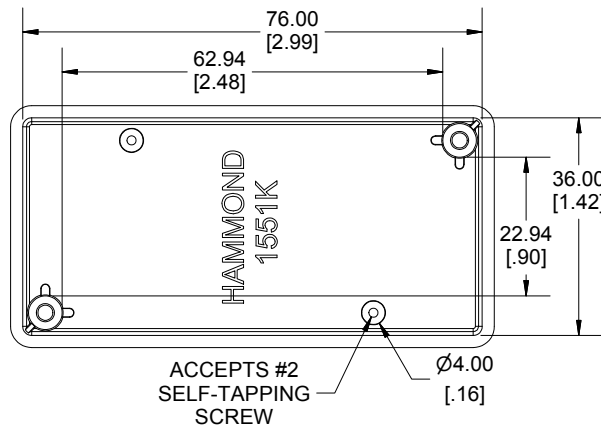

**INSIDE BOX**

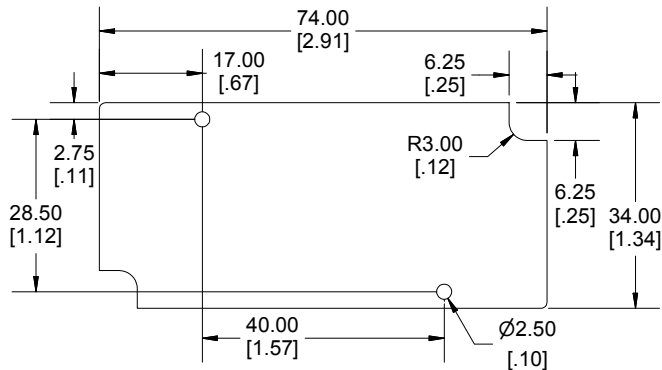

**MAXIMUM  
P.C. BOARD SIZE**

Dimensions:  
mm  
[inches]

<b>NOTE</b>	
Purchased assembly includes box, lid, 2 cover screws.	
Enclosure molded from general purpose ABS Plastic.	
Other materials / colours available consult factory.	
<b>Recommended Torque : (35-43) Ozf.in / (25-30) cN.m</b>	
<b>PART NUMBERS</b>	
1551L Enclosure	
Black Enclosure - Ral 9011 - UL94 - HB	1551LBK
Gray Enclosure - RAL 7035 - UL94 - HB	1551LGY
Tranlucent Blue - UL94 - HB	1551LTBU
<b>ACCESSORIES</b>	
Black Cover Screws #4 X 1/2" Self-tapping	1591TS100BK (Pkg 100)
Plated Cover Screws #4 X 1/2" Self-tapping	1591TS100 (Pkg 100)
P.C. Board Screws	1551ATS50 (Pkg 50)
#2 x 3/16" self-tapping (4.8mm)	1551ATS100 (Pkg 100)

