

Enclosures can be Factory Modified ( Milling, Drilling, Printing etc.)  
 Contact Factory [mjm@hammondmfg.com](mailto:mjm@hammondmfg.com) for quotes  
 Solid models of this enclosure available in STEP or IGES.  
 (Part number and text placement/orientation on our products are subject to change,  
 we do not recommend using them as a locating reference for modification purposes)

**NOTE**

Purchased assembly includes box, lid, 4 cover screws and installed brass inserts.  
 Enclosure molded from FRABS UL 94-V0 Plastic.  
 Other materials / colours available consult factory.  
**Recommended Torque : (43-50) Ozf.in / (30-35) cNm**

**PART NUMBERS**

1591XXM Enclosure	
Black Textured Enclosure	1591XXMBK
Gray Textured Enclosure	1591XXMGY
ACCESSORIES	
Black Cover Screws [M3-0.5 X10mm]	1591MS100BK (Pkg 100)
Plated Cover Screws [M3-0.5 X10mm]	1591MS100 (Pkg 100)
P.C. Board Screws	1593ATS60 (Pkg 50)
[#4 x 1/4" self-tapping (6.4mm)]	1593ATS100 (Pkg 100)

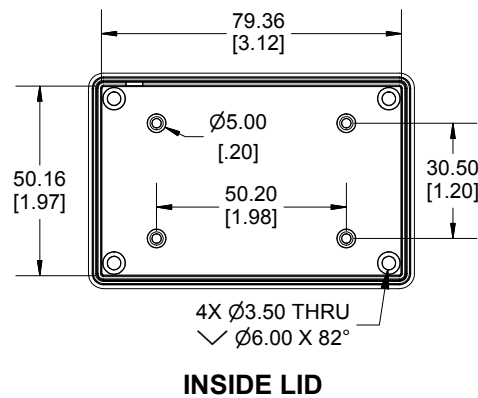
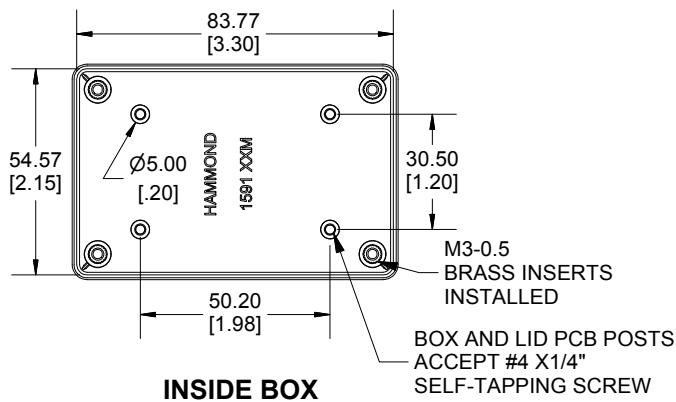

Dimensions:  
 mm  
 [inches]

**HAMMOND  
MANUFACTURING®**

**1591XXM**

[www.hammondmfg.com](http://www.hammondmfg.com)