



High Performance Couplings

- Stainless Steel Bellows
- Nickel Bellows
- Flexible Membrane (Disc)
 - **Torsionally rigid design**
 - **No moving parts**
 - **All-metal construction**
 - **Low inertia**

The operating principles of Flex B, Flex K, Flex Ni and Flex M offer the highest performance available with flexible couplings.

With excellent kinematic properties and torsional stiffness of a very high order, they are suitable for servo drives and satisfy the criteria for highly dynamic position and velocity control systems.

Bellows couplings have the greater torsional stiffness while Flex M have the more tolerant flexural system and feature dynamically balanced construction.



Stainless Steel Bellows Couplings

Set screw hubs

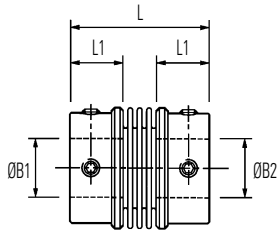

Ref. 530
Short type
for precisely aligned shafts

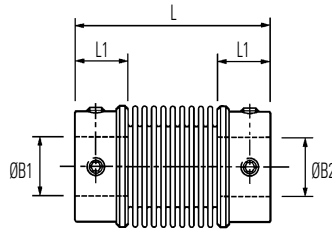

Ref. 532
Long type
for greater angular offsets
or axial motion

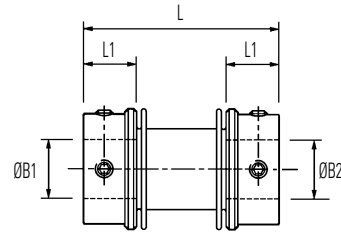

Ref. 534
Stretched type
for greater radial misalignment
and lower bearing loads

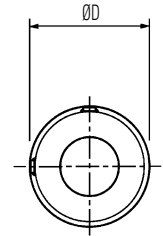

Typical

Clamp hubs

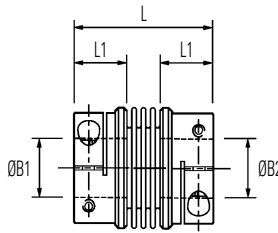

Ref. 536
Short type
for precisely aligned shafts

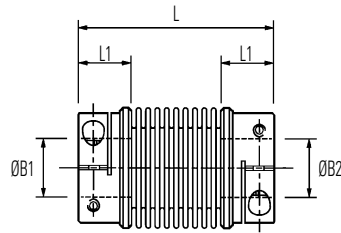

Ref. 538
Long type
for greater angular offsets
or axial motion

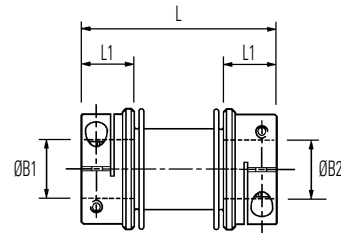

Ref. 540
Stretched type
for greater radial misalignment
and lower bearing loads

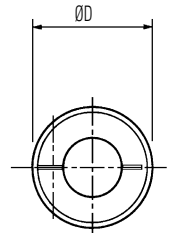

Typical

Comparative properties

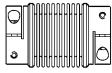
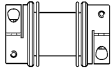
	Short	Long	Stretched
Parameter			
Peak Torque	2	1	3
Torsional Stiffness	3	1	2
Angular Compensation	2	3	1
Axial Compensation	2	3	1
Radial Compensation	1	3	2

The properties of the 3 types compared on a scale of 1 to 3.
3 = best.

Materials & Finishes

Hubs: Al. Alloy 2014T6 or 6026 LF and Clear anodised finish

Bellows: Spring quality stainless steel

Joint assembly: Copper C106, heat treated Zinc plate, clear passivate

Fasteners: Alloy steel, black oiled

Temperature Range

-40°F to + 248°F

(-40°C to +120°C)

Stainless Steel Bellows Couplings

DIMENSIONS & ORDER CODES

Coupling Size	Set Screw Hubs	Clamp Hubs	ØD in. (mm)	① L in. (mm) ±1.0	L1 in. (mm)	ØB1, ØB2 max in. (mm)	Fasteners			③ Moment of inertia kgm ² x 10 ⁻⁸	③ Mass kg x 10 ⁻³
							Screw	② Torque lb-in. (Nm)	Wrench in. (mm)		
COUPLING REF											
20	530.20	—	.79 (20.0)	1.22 (31.0)	.43 (11.0)	0.31 (8)	M4	20 (2.2)	0.08 (2)	90	18
	532.20	—		1.77 (45.2)						100	19
	534.20	—		1.72 (43.6)						90	18
	—	536.20		1.22 (31.0)			M2.5	11.6 (1.3)	0.08 (2)	90	16
	—	538.20		1.78 (45.2)						100	18
	—	540.20		1.72 (43.6)						90	17
26	530.26	—	1.02 (26.0)	1.48 (37.5)	.55 (14.0)	0.47 (12)	M5	40.9 (4.6)	0.10 (2.5)	350	35
	532.26	—		2.14 (54.3)						400	39
	534.26	—		2.09 (53.2)						370	34
	—	536.26		1.48 (37.5)			M3	21.5 (2.4)	0.10 (2.5)	330	34
	—	538.26		2.14 (54.3)						380	38
	—	540.26		2.09 (53.2)						350	33
34	530.34	—	1.34 (34.0)	1.57 (40.0)	.55 (14.0)	0.63 (16)	M5	40.9 (4.6)	0.10 (2.5)	975	58
	532.34	—		2.24 (57.0)						1128	65
	534.34	—		2.23 (56.6)						988	59
	—	536.34		1.57 (40.0)			M3	21.5 (2.4)	0.10 (2.5)	925	56
	—	538.34		2.24 (57.0)						1078	63
	—	540.34		2.23 (56.6)						938	57
41	530.41	—	1.61 (41.0)	1.96 (49.7)	.71 (18.0)	0.79 (20)	M6	67.3 (7.6)	0.11 (3)	2490	102
	532.41	—		2.81 (71.4)						2740	110
	534.41	—		2.78 (70.7)						2477	102
	—	536.41		1.96 (49.7)			M4	50.0 (5.6)	0.11 (3)	2390	99
	—	538.41		2.81 (71.4)						2660	107
	—	540.41		2.78 (70.7)						2377	99

IMPORTANT

Load capacity depends on application conditions: **see page 4** for details

PERFORMANCE

Coupling Size	Ref.	④ Peak torque lb-in. (Nm)	⑤ Max compensation			⑥ Flexural stiffness			
			Angular deg	Radial in. (mm)	Axial in. (± mm)	Torsional Nm / rad	Angular N / deg	Radial N / mm	Axial N / mm
20	530 & 536	17.7 (2.0)	2	.002 (0.06)	0.14 (0.35)	315	1.03	115	17.7
	532 & 538	8.8 (1.0)	6	.020 (0.50)	.038 (1.00)	170	0.33	6.7	7.8
	534 & 540	21.1 (2.5)	1.3	.007 (0.20)	.007 (0.20)	225	0.33	8.2	7.1
26	530 & 536	28.3 (3.2)	2	.002 (0.06)	.014 (0.36)	755	1.27	238	5.7
	532 & 538	14.2 (1.6)	6	.020 (0.50)	.039 (1.00)	380	0.39	8.2	3.3
	534 & 540	35.4 (4.0)	1.3	.007 (0.20)	.007 (0.20)	615	1.52	14.6	6.4
34	530 & 536	66.4 (7.5)	2.5	.003 (0.10)	.024 (0.60)	1740	1.34	227	6.6
	532 & 538	33.6 (3.8)	8	.039 (1.00)	.075 (1.90)	915	0.62	12.7	3.8
	534 & 540	83.2 (9.4)	1.5	.012 (0.30)	.012 (0.30)	1455	1.98	23.2	27.9
41	530 & 536	88.5 (10.0)	2.5	.006 (0.15)	.031 (0.80)	2880	1.58	144	13.1
	532 & 538	44.3 (5.0)	8	.047 (1.20)	.098 (2.50)	1310	0.52	9.3	3.8
	534 & 540	111 (12.5)	1.8	.016 (0.40)	.020 (0.50)	2245	2.30	19.2	7.2

- ① Length of supported thro' bore. Shafts can near-butt.
- ② Maximum recommended tightening torque.
- ③ Values apply with max bores.
- ④ **Peak torque.** Select a size where Peak Torque exceeds the application torque x service factor. (**see page 4**)
- ⑤ Max. compensation values are mutually exclusive.
- ⑥ Torsional stiffness values apply at 50% peak torque with no misalignment, measured shaft-to-shaft with largest standard bores. **Note that in some vendors' catalogs the given torsional stiffness applied to the un-mounted bellows element only, an unrepresentative calculated value.**

STANDARD BORES

Coupling Size	ØB1, ØB2 +0.0012/ -0 (+0.03mm/-0mm)																					
	(3)	1/8"	(4)	3/16"	(5)	(6)	1/4"	(8)	(9)	3/8"	(10)	(11)	(12)	1/2"	(14)	(15)	5/8"	(16)	(18)	(19)	3/4"	(20)
20	•	•	•	•	•	•	•	•														
26			•	•	•	•	•	•	•	•	•	•	•									
34					•	•	•	•	•	•	•	•	•	•	•	•	•	•	•			
41							•	•	•	•	•	•	•	•	•	•	•	•	•	•	•	•
Bore ref.	14	16	18	19	20	22	24	28	30	31	32	33	35	36	38	40	41	42	45	46	47	48
Corresponding bore adaptor					251		253	255			257			259				260				261

Diameters for which a bore adaptor is shown can be adapted to smaller shaft sizes. See page 58 for details of metal bore adaptors.

Stainless Steel Bellows Couplings

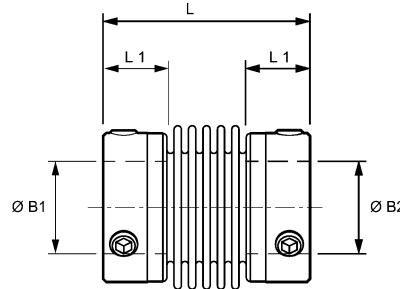

Ref. 550 & 551

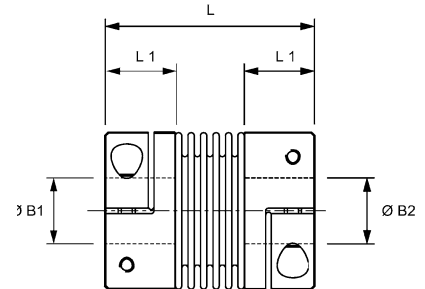

Ref. 554 & 555

DIMENSIONS & ORDER CODES

Coupling Size	Set Screw Hubs	Clamp Hubs	ØD in. (mm)	L in. (mm) ±0.04 (1)	L1 in. (mm)	ØB1, ØB2 Min in. (mm)	ØB1, ØB2 Max in. (mm)	Fasteners			Moment of inertia kgm ² x10-8	Mass kgx10-3	
								Screw	Torque lb-in. (Nm)	Wrench in. (mm)			
	COUPLING REF					+0.0012 (0.03) / -0							
10	550.10	-	0.31 (10.0)	0.91 (23.0)	0.24 (6.0)	0.039 (1.0)	0.16 (4.0)	M3	4.43 (0.5)	0.06 (1.5)	4	3	
	-	554.10		0.98 (25.0)	0.28 (7.0)			M1.6	0.89 (0.1)		5	2.6	
16	550.16	-	0.61 (15.5)	0.85 (21.5)	0.28 (7.0)	0.12 (3.0)	0.31 (8.0)	M3	4.43 (0.5)	0.06 (1.5)	17	4.1	
	551.16	-		0.93 (23.5)				0.28 (7.0)	M2		3.81 (.43)	19	4.6
	-	554.16		0.85 (21.5)								30	7.6
	-	555.16		0.93 (23.5)								33	7.9
20	550.20	-	0.79 (20.0)	1.04 (26.5)	0.33 (8.5)	0.12 (3.0)	0.47 (12.0)	M4	13.3 (1.50)	0.08 (2.0)	51	5.3	
	551.20	-		1.22 (31.0)				0.39 (10.0)	M2.5		7.52 (.85)	65	7.3
	-	554.20		1.04 (26.5)								75	9.5
	-	555.20		1.22 (31.0)								88	11.5
25	550.25	-	0.98 (25.0)	1.26 (32.0)	0.44 (11.3)	0.12 (3.0)	0.55 (14.0)	M4	13.3 (1.50)	0.08 (2.0)	80	6	
	551.25	-		1.65 (42.0)				0.5 (12.7)	M3		17.7 (2)	114	8
	-	554.25		1.26 (32.0)								225	17
	-	555.25		1.65 (42.0)								275	22
33	550.33	-	1.30 (33.0)	1.61 (41.0)	0.51 (13.0)	0.24 (6.0)	0.71 (18.0)	M6	26.6 (3.00)	0.12 (3.0)	613	29	
	551.33	-		1.89 (48.0)				0.63 (16.0)	M4		30.9 (3.50)	723	35
	-	554.33		1.61 (41.0)								950	48
	-	555.33		1.89 (48.0)								1036	51
41	550.41	-	1.61 (41.0)	1.90 (48.3)	0.53 (13.5)	0.24 (6.0)	0.94 (24.0)	M6	26.6 (3.00)	0.12 (3.0)	1285	32	
	551.41	-		2.17 (55.0)				0.87 (22.0)	M4		39.8 (4.50)	1885	51
	-	554.41		1.90 (48.3)								2150	59
	-	555.41		2.17 (55.0)								2750	79

PERFORMANCE

Coupling Size	Ref.	Peak torque lb-in. (Nm)	Max compensation ^⑤			Flexural Stiffness ^⑥		
			Angular deg	Radial in. (mm)	Axial in. (±mm)	Torsional Nm/rad	Radial N/mm	Axial N/mm
10	550 & 554	0.89 (0.1)	1.2	.004 (.12)	0.008 (.2)	65	10	14
16	550 & 554	8.85 (1.0)	1.0	.003 (.10)	0.008 (.2)	510	74	27
	551 & 555		1.5	.006 (.15)	0.01 (0.3)	380	31	20
20	550 & 554	13.3 (1.5)	1.5	.003 (0.10)	0.01 (0.3)	750	59	15
	551 & 555		2.0	.006 (0.15)	0.02 (0.4)	700	20	9
25	550 & 554	17.7 (2.0)	1.5	.006 (0.15)	0.01 (0.3)	1500	67	12
	551		1.5	.008 (0.20)	0.02 (0.4)	1300	21	11
	555		2.0	.010 (0.25)	0.02 (0.5)	1050	11	9
33	550, 5554 & 555	39.83 (4.50)	1.5	.003 (0.10)	0.01 (0.3)	6500	168	32
	551		2.0	.008 (0.20)	0.02 (0.5)	4200	41	20
41	550 & 554	88.5 (10.0)	1.5	.006 (0.15)	0.16 (0.4)	8100	120	27
	551 & 555		2.0	.012 (0.30)	0.02 (0.6)	6800	29	17

Materials & Finishes

Hubs: Al. Alloy [Clamp hubs size 66 and larger - steel]

Bellows: Spring quality stainless steel

Fasteners: Alloy steel, black oiled

Temperature Range

-22°F to + 248°F
(-30°C to +120°C)

Stainless Steel Bellows Couplings

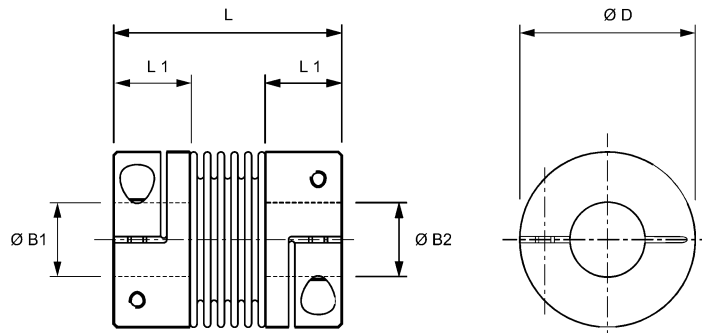

Ref. 554 & 555

Typical

CLAMP HUBS

DIMENSIONS & ORDER CODES

Coupling Size	Set Screw Hubs	Clamp Hubs	ØD in. (mm)	L in. (mm) ±0.04 (1)	L1 in. (mm)	ØB1, ØB2 Min in. (mm)	ØB1, ØB2 Max in. (mm)	Fasteners			Moment of inertia kgm ² x10 ⁻⁸	Mass kgx10 ⁻³
								Screw	Torque lb-in. (Nm)	Wrench in. (mm)		
	COUPLING REF					+0.0012 (0.03) / -0						
45	-	554.45	1.77 (45.0)	2.48 (63.0)	0.77 (19.5)	0.39 (10)	1.00 (25.4)	M5	70 (8.0)	.157 (4.0)	3560	54
	-	555.45		2.78 (71.0)							4560	104
56	-	554.56	2.20 (56.0)	2.56 (65.0)	0.96 (24.5)	0.39 (10)	1.18 (30.0)	M6	132 (15.0)	.196 (5.0)	13930	215
	-	555.56		2.87 (73.0)							14930	235
66	-	554.66	2.60 (66.0)	3.11 (79.0)	1.14 (29.0)	0.47 (12)	1.26 (32.0)	M8	354 (40.0)	.236 (6.0)	31360	390
	-	555.66		3.50 (89.0)							34360	490
82	-	554.82	3.23 (82.0)	3.58 (91.0)	1.32 (33.5)	0.51 (13)	1.65 (42.0)	M10	740 (84.0)	.315 (8.0)	183930	1150
	-	555.82		4.02 (102.0)							193930	1250
90	-	554.90	3.54 (90.0)	3.98 (101.0)	1.50 (38.0)	0.87 (22)	1.77 (45.0)	M12	1100 (125.0)	.394 (10.0)	305980	1875
	-	555.90		4.45 (113.0)							325980	1975
110	-	554.110	4.33 (110.0)	4.133 (105.0)	1.50 (38.0)	1.18 (30)	2.36 (60.0)	M12	1100 (125.0)	.394 (10.0)	654095	2330
	-	555.110		4.57 (116.0)							674095	2430
122	-	554.122	4.80 (122.0)	4.41 (112.0)	1.65 (42.0)	1.38 (35)	2.56 (65.0)	M12	1100 (125.0)	.394 (10.0)	1124450	3540
	-	555.122		4.84 (123.0)							1154450	3640

PERFORMANCE

Coupling Size	Ref.	Peak torque lb-in. (Nm)	Max compensation ^⑤			Flexural Stiffness ^⑥		
			Angular deg	Radial in (mm)	Axial in. (±mm)	Torsional Nm/Rad	Radial N/mm	Axial N/mm
45	554	159 (18)	1.5	.008 (0.20)	.020 (0.5)	20000	790	100
	555		2.0	.010 (0.25)	.020 (0.5)	15000	970	85
56	554	266 (30)	1.5	.006 (0.15)	.024 (0.6)	38000	720	50
	555		2.0	.010 (0.25)	0.04 (1.0)	28000	225	28
66	554	531 (60)	1.5	.006 (0.15)	.024 (0.6)	75000	1150	90
	555		2.0	.010 (0.25)	.040 (1.0)	50000	340	50
82	554	1328 (150)	1.5	.008 (0.20)	.020 (0.5)	155000	1200	145
	555		2.0	.010 (0.25)	.020 (0.5)	105000	400	185
90	554	1770 (200)	1.5	.008 (0.20)	.020 (0.5)	175000	2020	145
	555		2.0	.010 (0.25)	.031 (0.8)	120000	595	82
110	554	2655 (300)	1.5	.008 (0.20)	.020 (0.5)	502000	2500	280
	555		2.0	.010 (0.25)	.031 (0.8)	285000	460	145
122	554	4425 (500)	1.5	.008 (0.20)	.020 (0.5)	690000	6300	100
	555		2.0	.010 (0.25)	.040 (1.0)	320000	1400	85

- ① Length of supported bore
- ② Maximum recommended tightening torque
- ③ Values apply with Max. Bores

- ④ Peak Torque. Select a size where Peak Torque exceeds the application torque x service factor (see page 4)
- ⑤ Max. compensation values are mutually exclusive
- ⑥ Torsional stiffness values apply at peak torque with no misalignment

Materials & Finishes

Hubs: Al. Alloy [Clamp hubs size 66 and larger - steel]
Bellows: Spring quality stainless steel
Fasteners: Alloy steel, black oiled

Temperature Range

-22°F to +248°F
 (-30°C to +120°C)

Stainless Steel Bellows Couplings

SPLIT CLAMP HUBS

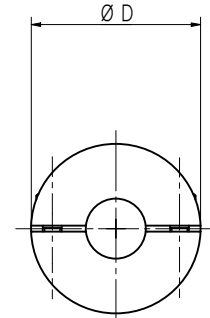
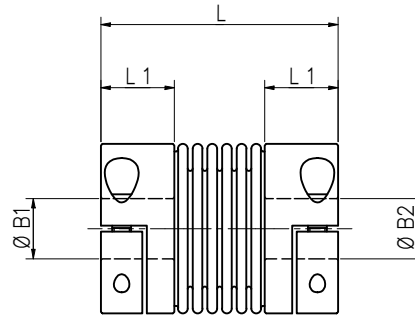

Ref. 592 & 593

Typical

DIMENSIONS & ORDER CODES

Coupling Size	Split Clamp Hubs	ØD in. (mm)	L in. (mm) ±0.04 (1)	L1 in. (mm)	ØB1, ØB2 Min in. (mm)	ØB1, ØB2 Max in. (mm)	Fasteners			Moment of inertia kgm ² x10-8	Mass kgx10-3
							Screw	Torque lb-in. (Nm)	Wrench in. (mm)		
COUPLING REF											
45	592.45	1.77 (45.0)	2.48 (63.0)	0.77 (19.5)	0.39 (10)	1.00 (25.4)	M5	70 (8.0)	.157 (4.0)	3560	100
	593.45		2.78 (71.0)							4560	150
56	592.56	2.20 (56.0)	2.56 (65.0)	0.96 (24.5)	0.39 (10)	1.18 (30.0)	M6	132 (15.0)	.196 (5.0)	13930	300
	593.56		2.87 (73.0)							14930	320
66	592.66	2.60 (66.0)	3.11 (79.0)	1.14 (29.0)	0.47 (12)	1.26 (32.0)	M8	354 (40.0)	.236 (6.0)	31360	500
	593.66		3.50 (89.0)							34360	600
82	592.82	3.23 (82.0)	3.58 (91.0)	1.32 (33.5)	0.51 (13)	1.65 (42.0)	M10	740 (84.0)	.315 (8.0)	183930	900
	593.82		4.02 (102.0)							193930	950

PERFORMANCE

Coupling Size	Ref.	Peak torque lb-in. (Nm)	Max compensation ⑤			Flexural Stiffness ⑥		
			Angular deg	Radial in. (mm)	Axial in. (±mm)	Torsional Nm/Rad	Radial N/mm	Axial N/mm
45	592	159 (18)	1.5	.008 (0.20)	.020 (0.5)	20000	790	100
	593		2.0	.010 (0.25)	.020 (0.5)	15000	970	85
56	592	266 (30)	1.5	.006 (0.15)	.024 (0.6)	38000	720	50
	593		2.0	.010 (0.25)	.040 (1.0)	28000	225	28
66	592	531 (60)	1.5	.006 (0.15)	.024 (0.6)	75000	1150	90
	593		2.0	.010 (0.25)	.040 (1.0)	50000	340	50
82	592	1328 (150)	1.5	.008 (0.20)	.020 (0.5)	155000	1200	145
	593		2.0	.010 (0.25)	.020 (0.5)	105000	400	185

- ① Length of supported bore
- ② Maximum recommended tightening torque
- ③ Values apply with Max. Bores

- ④ Peak Torque. Select a size where Peak Torque exceeds the application torque x service factor (see page 4)
- ⑤ Max. compensation values are mutually exclusive
- ⑥ Torsional stiffness values apply at peak torque with no misalignment

Materials & Finishes

Hubs: Al. Alloy
Bellows: Spring quality stainless steel
Fasteners: Alloy steel, black oiled

Temperature Range

-22°F to + 248°F
 (-30°C to +120°C)

Stainless Steel Bellows Couplings

FLANGE MOUNTED

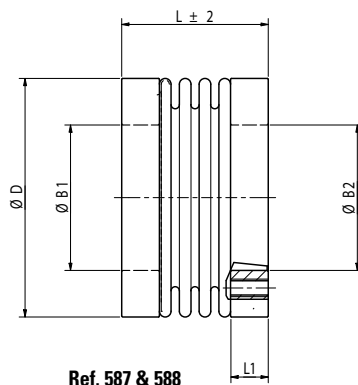

Ref. 587 & 588

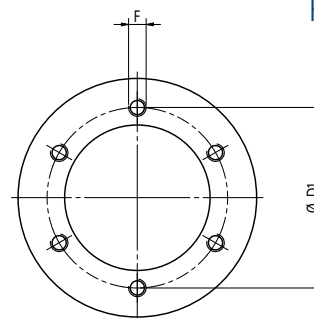

Typical

DIMENSIONS & ORDER CODES

Coupling Size	Order Codes	ØD in. (mm)	L in. (mm)	ØB1, ØB2 min/max in. (mm) (H7)	D1 in. (mm)	L1 in. (mm) ^①	F Screw	Moment of inertia kgm ² x10 ⁻⁸ ^②	Mass kgx10 ⁻³ ^②	Max speed (min-1)
COUPLING REF										
45	587.45.49	1.77 (45.0)	1.42 (36)	0.87 (22)	1.22 (31)	0.24 (6)	M5	3560	110	11500
	588.45.49		1.73 (44)					4560	115	
56	587.56.54	2.20 (56.0)	1.18 (30)	1.10 (28)	1.46 (37)	0.28 (7)	M5	13930	160	11000
	588.56.54		1.50 (38)					14930	170	
66	587.66.61	2.60 (66.0)	1.61 (41)	1.50 (38)	1.81 (46)	0.41 (10.5)	M6	31360	330	9100
	588.66.61		2.01 (51)					34360	370	
82	587.82.70	3.23 (82.0)	1.97 (50)	1.97 (50)	2.44 (62)	0.51 (13)	M6	183930	690	7000
	588.82.70		2.44 (62)					193930	750	

PERFORMANCE

Coupling Size	Ref.	Peak torque lb-in. (Nm) ^③	Max compensation ^④			Flexural Stiffness ^⑤		
			Angular deg	Radial in. (mm)	Axial in. (±mm)	Torsional Nm/Rad	Radial N/mm	Axial N/mm
45	587.45	159 (18)	1.5	.008 (0.20)	.020 (0.5)	20000	205	50
	588.45		2.0	.010 (0.25)	.020 (0.5)	15000	87	36
56	587.56	266 (30)	1.5	.006 (0.15)	.024 (0.6)	38000	720	50
	588.56		2.0	.010 (0.25)	.040 (1.0)	28000	225	25
66	587.66	531 (60)	1.5	.006 (0.15)	.024 (0.6)	75000	1150	90
	588.66		2.0	.010 (0.25)	.040 (1.0)	50000	340	50
82	587.82	1328 (150)	1.5	.008 (0.20)	.020 (0.5)	155000	2020	145
	588.82		2.0	.010 (0.25)	.040 (1.0)	105000	595	85

① Length of supported bore/thread depth

② Values apply with Max. Bores

③ Peak Torque. Select a size where Peak Torque exceeds the application torque x service factor (see page 4)

④ Max. compensation values are mutually exclusive

⑤ Torsional stiffness values apply at peak torque with no misalignment

Materials & Finishes

Flanges: Steel

Bellows: Spring quality stainless steel

Temperature Range

-22°F to + 248°F

(-30°C to +120°C)