



SPECIFICATIONS

MODEL NO.
OBO-1205D-A2

PART NAME
Magnetic Transducer

SHEET
1 OF 4

ALTERNATION HISTORY

Marking	Date	ECN. NO.	REV.	Description	Page	PREPARE BY	APPROVE BY
1	AUG,19'05	0505008	F	1.Conformity RoHS Directive (2002/95/EC) Requests. 2.Increase by Soldering Condition & Pb-Free" Tape.	4		
2	NOV,29'07	DG0711009	G	1. Change wave soldering & hand soldering Temperature 2. Change "Pb-Free" Tape to "RoHS" Tape	4	王志偉	Darren

REV.	DATE	PREPARED BY	CHECKED BY	APPROVED BY
G	NOV,29,2007	王志偉	Darren	Darren

MODEL NO : OBO-1205D-A2

Features : Conformity RoHS Directive (2002/95/EC) Requests.

1.General Specifications :

Items	Specification
※ Sound Pressure Level	83 dB min./10cm/DC 5V
Rated Voltage	DC 5V
※ Resonant Frequency	2300 ± 400 Hz
※ Rated Current	30 mA max./DC 5V
Operating Voltage	DC 3 to 7V
Housing Material	NORYL
Operating Temp. Range	-25°C to +70°C
Storage Temp Range	-30°C to +85°C
Weight	2.0 gms

2.Mechanical Layout and Dimensions :

※ Value applying rated voltage.(DC)

2.1 Shape & Dimensions

Unit:mm Tolerance:±0.5

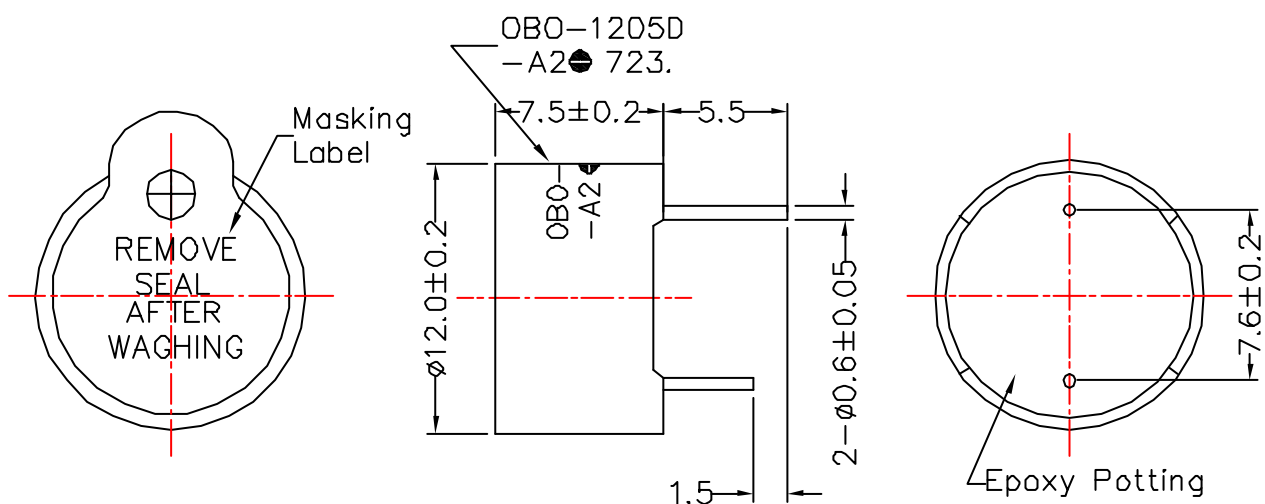

Wave Solder and Wash Allowed

2.2 Meaning of Stamp Mark

723 : Production Period

7 : Year 2007 (last 1 figures of the year)

23 : Week (01~55)

3.Soldering Condition : 2

3.1 Wave Soldering

Peak temperature	Dipping time	Soldering
+ 260°C	5 seconds	1 time

3.2 Hand Soldering

Iron Tip Temperature	Soldering time
+ 380°C	Duration 3 seconds Max.

4.Packing Information :

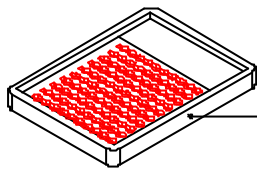

TRAY
100pcs/TRAY
(240*160 mm)

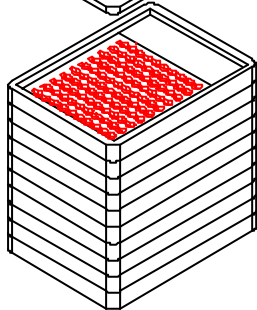
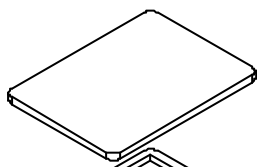

1000pcs/10 TRAY

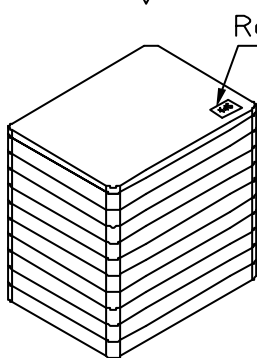

RoHS Tape

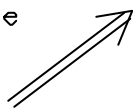

2

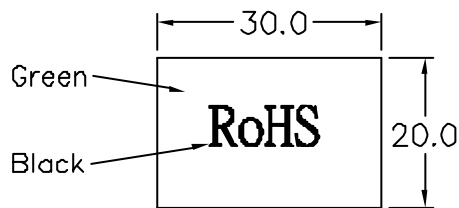

Green

Black

RoHS Tape
(30*20 mm)

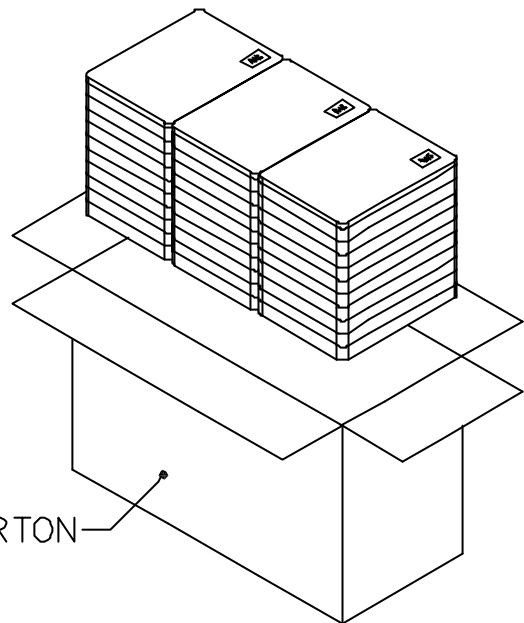

CARTON

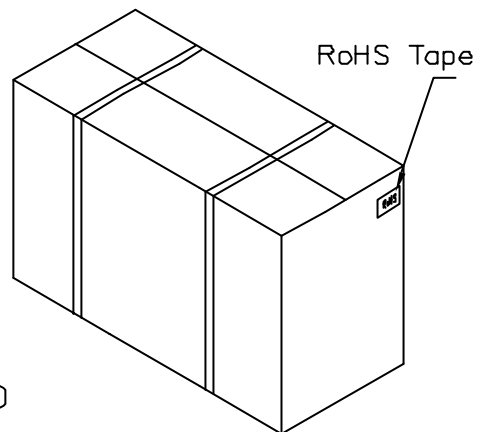

RoHS Tape

3000pcs/CARTON
(50.5*26*28CM)