



**MODEL NO : OBO-17240SA**

Features : External drive.

Conformity RoHS Directive(2002/95/EC) Requests.

**1. General Specifications:**

	Items	Spec.
1.1	Sound Pressure Level	82dB Min.at 4000Hz/9.0Vp-p,Square wave/10cm 72dB Min. at 1Vms/4000Hz,sine wave/10cm
1.2	Capacitance	15,000pF±30% at 100Hz
1.3	Current Consumption	5mA Max. at 4000Hz/9.0Vp-p
1.4	Allowable Input Voltage	20Vp-p
1.5	Case Material	PPS( Black )
1.6	Lead Pin Material	Plated Brass(Au)
1.7	Operating Temp. Range	-20°C to +70°C
1.8	Storage Temp. Range	-40°C to +85°C
1.9	Weight	1.3 gms

OBO PRO.2 INC.  
2011.11.25  
文件发行章

**2. Test Method :**

2.1 Standard Test Diagram

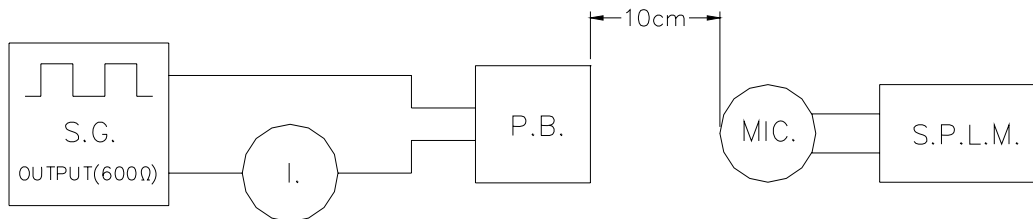

- S.G. : GAG-808G Audio Ggenerator or Equivalent
- S.P.L.M. : Sound Pressure Level Meter IEC651 TYPE2
- I. : GDM-8145 Multimeter or Equivalent
- P.B. : Piezoelectric Buzzer

Note:please pay attention never to be applied DC voltage to piezo sounder.

2.2 Measuring condition

Part shall be measured under a condition

(Temperature: +5°C to +35°C, Humidity: 45% to 85%R.H.)

unless the standard condition (Temperature: +25±3°C,

Humidity: 60±10%R.H.) is regulated to measure.

### 3. Mechanical Layout and Dimensions:

#### 3.1 Dimendions

Tolerance:  $\pm 0.3\text{mm}$  Unit: mm

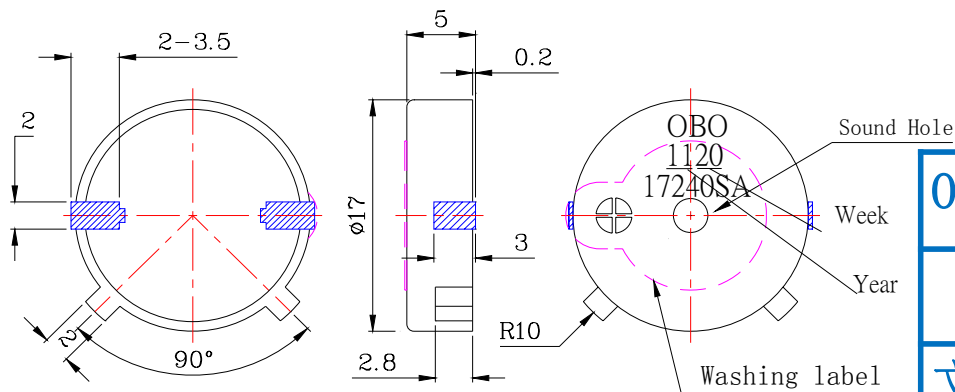

OBO PRO.2 INC.

2011.11.25

文件发行章

Recommended land pattern

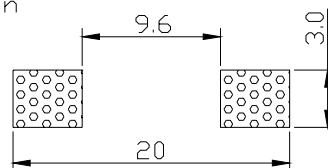

#### 3.2. Environment-related substances to be controlled.

◎ Piezoelectric Ceramic Disc.

RoHs Annex:

Application of lead, mercury, cadmium and hexavalent chromium, which are exempted from the requirement of article 4(1).

\* Lead in electronic ceramic parts.(e.g. piezoelectronic devices).

**4. Soldering Condition :**

**4.1 Reflow Soldering**

Recommendable reflow Soldering condition is flows.

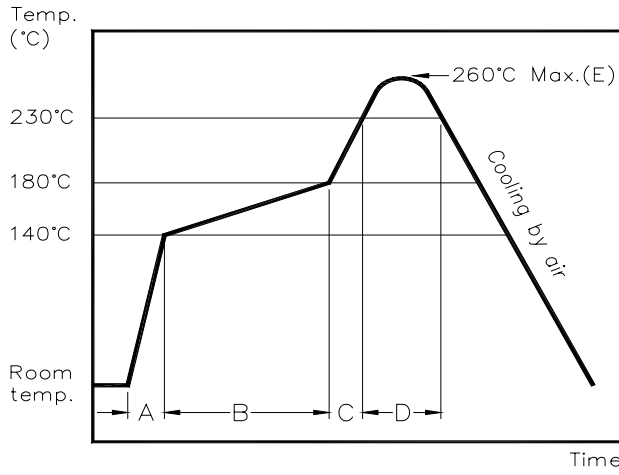

NO.	Items	Condition	Unit
A	Temp. rise gradient	1 ~ 4	°C/sec
B	Heating time	50~150	sec
	Heating temperature	140~180	°C
C	Temp. rise gradient	1 ~ 4	°C/sec
D	Time over 230°C	48 Max.	sec
E	Peak temperature	260°C Max.	°C
	Peak-temp. hold time	Momentary	sec
Soldering			2 times

OBO PRO. 2 INC.  
2011.11.25  
文件发行章

Note: It's requested that second reflows soldering should be executed after heat of product goes down to normal temperature.

**4.2 Hand Soldering**

Soldering iron temperature 350°C less than 5 second.

5. Packing Information :

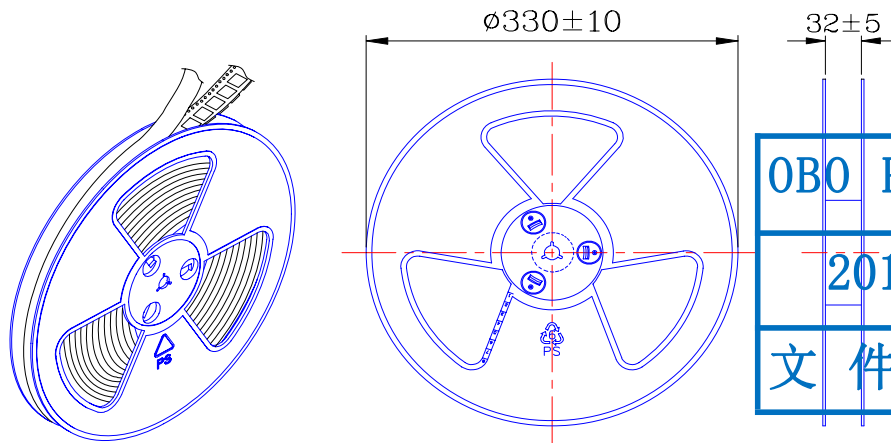

1 Reel : 400PCS

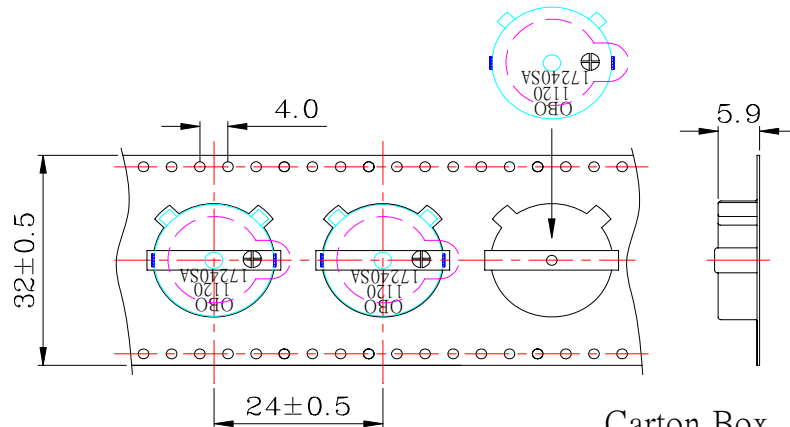

Carton Box  
(10 Inner Box)

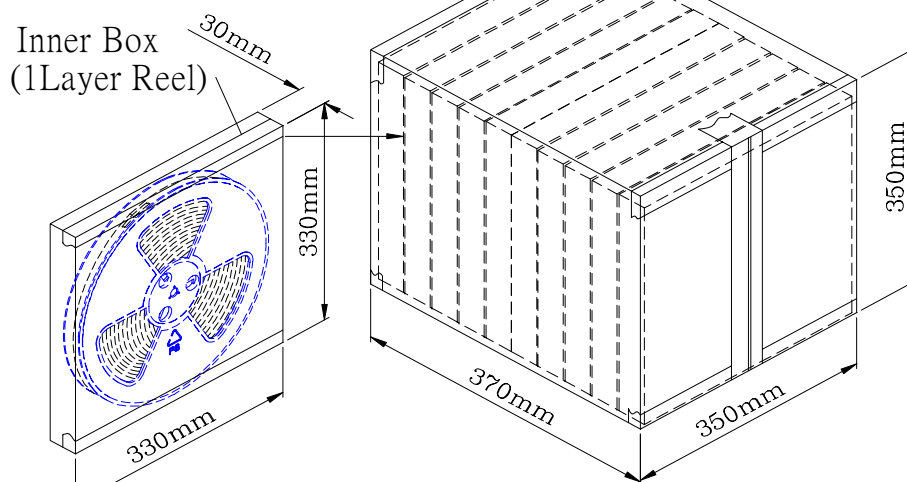

Inner Box	330mmx330mmx30mm	1x400PCS=400PCS
Carton Box	350mmx350mmx370mm	10x400PCS=4000PCS