

# FLYOVER® QSFP CABLE ASSEMBLIES

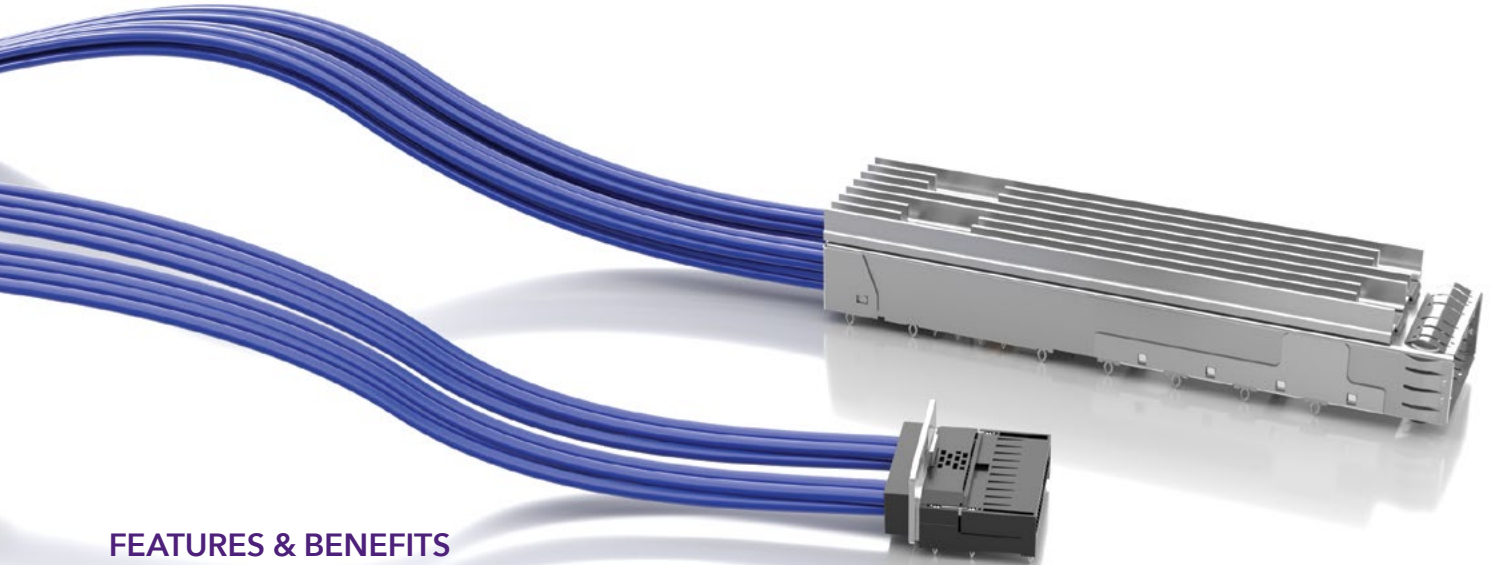

## FEATURES & BENEFITS

QSFP28, QSFP-DD and QSFP-D8 systems utilize Samtec Flyover® technology to route data above lossy PCB, simplifying board layout and extending signal reach. The modular design enables optimized systems that improve heat management, increase signal integrity performance, build in scalability for future upgrades and reduces costs by creating a multifunction board.

NRZ	PAM4
56 Gbps	112 Gbps

## FLYOVER® QSFP SYSTEM

- 4 Channels (x4 bidirectional, 8 differential pairs)
- Up to 400 Gbps aggregate (112 Gbps PAM4)
- Compatible with all MSA QSFP pluggables
- Multiple heat sink options available for optimal dissipation
- Eye Speed® 30 or 34 AWG twinax cable
- Multiple end 2 options for design flexibility
- Evaluation Kits available (REF-205303-X.XX-XX and REF-200471-X.XX-XX), visit [samtec.com/kits](http://samtec.com/kits)



Localized press-fit control and power contacts eliminate the need for a secondary cable and connector



High-speed contacts directly soldered to Eye Speed® ultra low skew twinax

## FLYOVER® QSFP DOUBLE DENSITY

- 8 Channels (x8 bidirectional, 16 differential pairs)
- Up to 400 Gbps aggregate (56 Gbps PAM4)
- Belly-to-belly mating for maximum density
- Backward compatible with QSFP modules
- Multiple heat sink options available for optimal dissipation
- Variety of end 2 options
- Evaluation Kits available (REF-205605-X.XX-XX and REF-203423-X.XX-XX), visit [samtec.com/kits](http://samtec.com/kits)

## 800G FLYOVER® DOUBLE DENSITY

- 8 Channels (x8 bidirectional, 16 differential pairs)
- Up to 800 Gbps aggregate (112 Gbps PAM4)
- Belly-to-belly mating for maximum density
- Backward compatible with QSFP & QSFP-DD modules
- Multiple heat sink options available for optimal dissipation
- Variety of end 2 options

# 800G FLYOVER® QSFP DOUBLE DENSITY

FQSFP	D8	CABLE TYPE	FOOTPRINT	CABLE LENGTH	END 2 OPTION
-------	----	------------	-----------	--------------	--------------

## FQSFP-D8

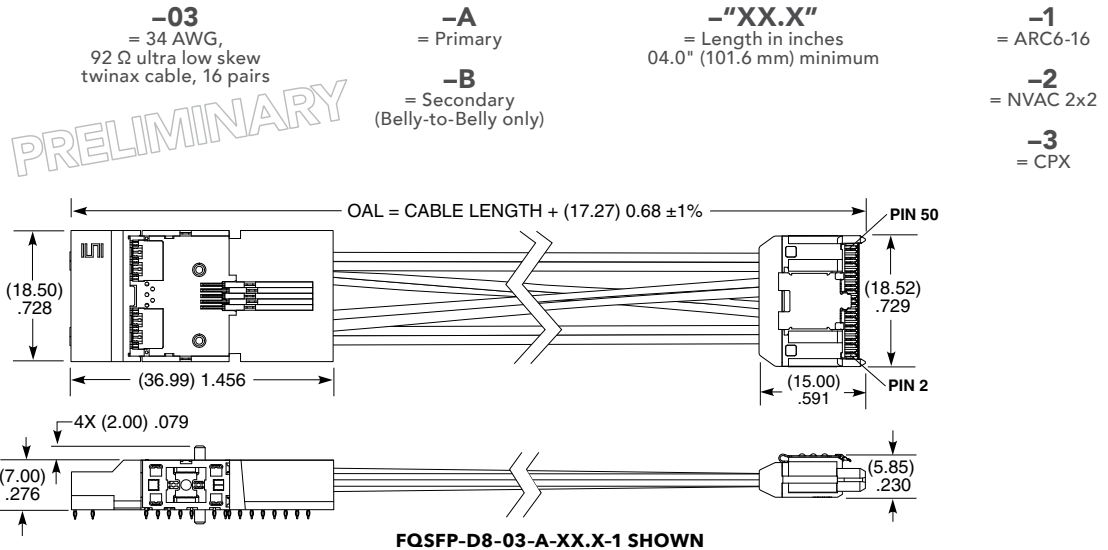

QSFP	D8	STACK	NO. OF PORTS	OPTION	STYPE
------	----	-------	--------------	--------	-------

## QSFP-D8

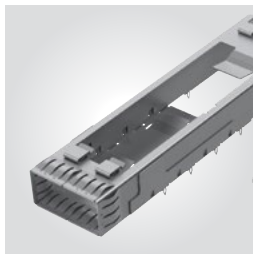

- 1**  
= Single Stack
- 1**  
= One Port
- 2**  
= Two Ports
- S**  
= Spring Fingers
- F**  
= Flyover

**PRELIMINARY**

NO. OF PORTS	A	B	C
-1	(20.96) .825	(19.87) .782	(19.00) .748
-2	(39.96) 1.573	(38.87) 1.530	(38.00) 1.496

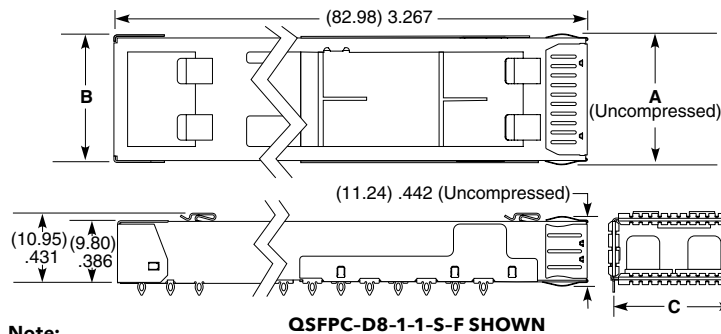

**Note:**  
Some sizes, styles and options are non-standard, non-returnable.

HS-QSFP	D8	HEAT SINK HEIGHT
---------	----	------------------

## HS-QSFP-D8

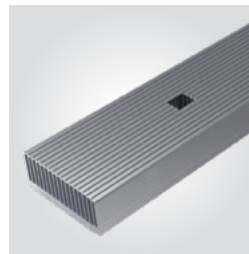

- 1**  
= (6.20 mm) .244" height
- 2**  
= (12.00 mm) .472" height

**PRELIMINARY**

HEAT SINK HEIGHT	A
-1	(6.29) .244
-2	(12.00) .472

