

HIGH-DENSITY HIGH-SPEED I/O SYSTEM

(0.635 mm) .025" PITCH • HDLSP/HDI6/HDC SERIES



HDLSP

Mates:
HDI6

SERIES	NO. OF POSITIONS	LENGTH	OPTION
--------	------------------	--------	--------

SPECIFICATIONS

Cable:
32 AWG low skew pair cable

Insulator Material:
LCP

Terminal Material:
Phosphor Bronze

Jacket Material:
PVC

Insulator:
Dielectric

Conductors:
Copper

Braid:
Tinned Copper

Covers:
Diecast Zinc Alloy

Current Rating:
1.5 A per pin
(4 adjacent pins powered)

HDLSP = High-density Low Skew Pair Cable	-035 (Per Row) = 12 Pairs per side	-"XXXX" = Length in millimeters -1000, -2000 (Standard lengths)	-L = Positive Latch
--	---	---	-------------------------------

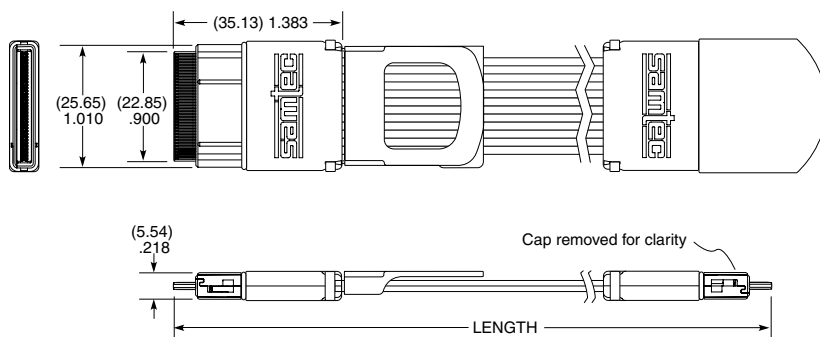

HDLSP-035-XXX-L SHOWN
Some components not shown for clarity

Note:
Some lengths, styles and options are non-standard, non-returnable.

HDI6

Mates:
HDLSP

HDI6	NO. OF POSITIONS	01	RA	"X"R	SERIES	NO. OF POSITIONS	OPTION	L
------	------------------	----	----	------	--------	------------------	--------	---

SPECIFICATIONS

Insulator Material:
Black LCP

Terminal Material:
Phosphor Bronze

Plating:
Au or Sn over 50 μ" (1.27 μm) Ni

Current Rating:
1.5 A per pin
(4 adjacent pins powered)

Operating Temp Range:
-25 °C to +105 °C

Voltage Rating:
150 VAC

-035 (Per Row)	-TR = Tape & Reel	-01 = Cage	-FR = Full Reel Tape & Reel (must order maximum quantity per reel; contact Samtec for quantity breaks)	-035 = Number of positions	-01 = No gasket
--------------------------	-----------------------------	----------------------	--	--------------------------------------	---------------------------

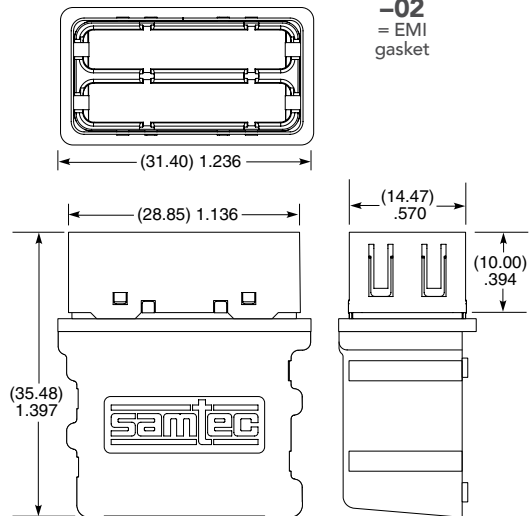
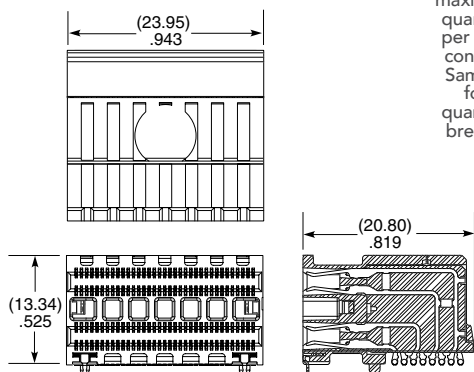

HDC-035-02-L SHOWN

Notes:
For HT3.1 see www.samtec.com/ht3 and specify part number ASP-149117-01

Some lengths, styles and options are non-standard, non-returnable.