

Product Data Sheet

Product Datasheet

C2 Oxygen Sensor

Document Purpose

The purpose of this document is to present the performance specification of the C2 oxygen gas sensor.

This document should be used in conjunction with the Operating Principles (OP02) and the Product Safety Datasheet (PSDS 4).

The data provided in this document are valid at 20°C, 50% RH and 1013 mBar for 3 months from the date of sensor manufacture.

Output signal can drift below the lower limit over time. For guidance on the safe use of the sensor, please refer to the Operating Principles (OP02).

Product Data Sheet

Performance Characteristics

MEASUREMENT

Operating Principle	2-electrode electrochemical
Measurement Range	0 - 25% O ₂
Maximum Overload	30% O ₂
Filter	None
Output Signal*	0.42 ± 0.06 mA in air
Response Time (T₉₅)*	< 10 seconds
Linearity	Linear

ELECTRICAL

Recommended Load Resistor | 47 Ω

MECHANICAL

Housing Material:	
Body	Nickel plated steel
Current Collectors	Nickel
Orientation Sensitivity	None

ENVIRONMENTAL

Operating Temperature Range	-20°C to +50°C
Temperature Coefficient	0.2% signal/°C
Recommended Storage Temp	0°C to 20°C
Operating Pressure Range	Atmospheric ± 10%
Pressure Coefficient	0.01% signal / mBar
Operating Humidity Range	0 - 99% RH non-condensing

LIFETIME

Long Term Output Drift	<5% signal loss/year
Expected Operating Life	18 months in air
Storage Life	6 months in CTL container

Product Dimensions

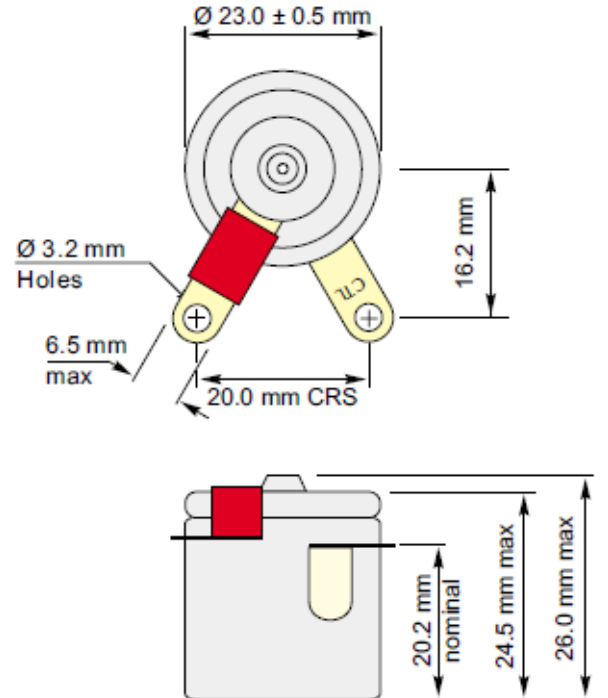

All dimensions in mm
All tolerances ±0.15 mm unless otherwise stated

IMPORTANT NOTE: Connection should be made via PCB sockets only. Soldering to the pins will seriously damage your sensor.

* Specifications are valid at 20°C, 50% RH and 1013 mBar, using City Technology recommended circuitry. Performance characteristics outline the performance of sensors supplied within the first 3 months. Output signal can drift below the lower limit over time.

SAFETY NOTE

This sensor is designed to be used in safety critical applications. To ensure that the sensor and/or instrument in which it is used, are operating properly, it is a requirement that the function of the device is confirmed by exposure to target gas (bump check) before each use of the sensor and/or instrument. Failure to carry out such tests may jeopardize the safety of people and property.

Every effort has been made to ensure the accuracy of this document at the time of printing. In accordance with the company's policy of continued product improvement City Technology Limited reserves the right to make product changes without notice. The products are always subject to a programme of improvement and testing which may result in some changes in the characteristics quoted. As the products may be used by the client in circumstances beyond the knowledge and control of City Technology Limited, we cannot give any warranty as to the relevance of these particulars to an application. It is the clients' responsibility to carry out the necessary tests to determine the usefulness of the products and to ensure their safety of operation in a particular application.