

OOA101 GAS SENSOR

001-05
Issue 2

Oxygen (O₂) Gas Sensor Honeywell EnviteC Series



Oxygen Sensor:
OOA101

WE KEEP YOUR DEVICES OPERATING AT THEIR BEST

Honeywell Healthcare Solutions GmbH formerly known as EnviteC-Wismar GmbH develops and manufactures highly specialized products for medical applications and innovative products within the gas measurement technology for environmental, industrial and safety applications.

The company trusts in the quality of advanced production methods and processes. The result are oxygen sensors for automotive emission gas analysers, which share the same extraordinary quality, excellent signal stability and reliable response for accurate readings.

Honeywell research and development activities are consistently aligned to customer and market needs – identification and optimization of sustainable product solutions are the main concerns of the company.

ADVANTAGES

- Certified quality management system
- Accurate and reliable response
- Excellent selectivity against CO₂
- Excellent signal stability
- High product quality
- Short delivery times
- Technical support
- Made in Germany

FROM STANDARD SENSORS TO CUSTOMIZED SENSORS

Experienced Honeywell engineers analyze customer requirements. This input is used for different standard and OEM applications, and ongoing support is provided right up to the final integration in the solution.

Honeywell designs customized sensors characterized by a maximum possible degree of precision.

INTENDED USE

These sensors are designed for measuring the partial pressure of oxygen in automotive exhaust gas measuring equipment.

PORTFOLIO

The EnviteC sensor family is part of the extensive line of Honeywell gas sensors. To learn more about the product, or the many other gas sensors in this series, [click here](#).

HONEYWELL HEALTHCARE SOLUTIONS GMBH GAS SENSORS

OOA101

TABLE 1. TECHNICAL SPECIFICATIONS

Characteristic	Measure
Measurement range	0 % ... 100 % oxygen (at atmospheric pressure)
Output in ambient air	7 mV ... 13 mV
Electrical interface	3-pin (Molex® 22-04-1031)
Accuracy	0 % ... 3.3 % oxygen: ±0.1 % absolute 3.4 % ... 100 % oxygen: ±3 % relative
Linearity error	< 3 % relative
Response time	< 5 s to 90 % of final value; < 40 s fall time from 20.95 % to 0.1 % oxygen (when 100 % nitrogen applied)
Zero offset voltage	< 40 µV in 100 % nitrogen
Cross interference	< 0.1 % oxygen response to: 16 % CO ₂ balance N ₂ ; 6 % CO balance N ₂ ; 3000 ppm NO balance N ₂ ; 2000 ppm n-hexane balance N ₂
Influence of humidity	-0.03 % rel. per %RH at 25°C
Pressure range	0.6 bar ... 2 bar (ppO ₂ 0 ... 1250 mbar O ₂)
Influence of pressure	proportional to change in oxygen partial pressure
Operating temperature	0°C ... 50°C
Temperature compensation	built-in NTC compensation
Effect of temperature compensation (steady state)	between +25°C and +40°C: 3 % relative error between 0°C and +50°C: 8 % relative error
Operating humidity	0 % ... 99 %RH non-condensing
Long-term output drift	< 1 % volume oxygen per month, typically < -15 % relative over lifetime
Storage temperature	-20°C ... 50°C
Recommended storage	5°C ... 15°C
Recommended load	≥ 10 kOhm
Warm-up time	< 30 minutes, after replacement of sensor
Nominal sensor lifetime	≥ 500 000 % volume oxygen hours
Weight	approximately 28 grams
Part number	E01-00-0030

All specifications are applicable at standard conditions: 1013 hPa, 25°C dry ambient air
Technical information is subject to change without notice.

Product Dimensions

All dimensions in mm

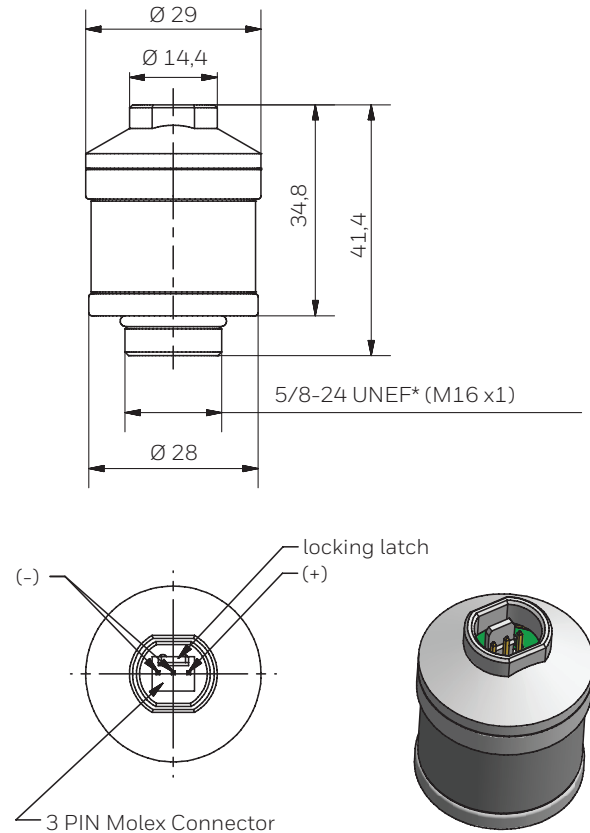

General tolerances ISO 2768-c
*Intermediate thread: Metric/Unified Extra Fine

For more information

Honeywell Sensing Solutions services its customers through a worldwide network of sales offices and distributors. For application assistance, current specifications, pricing, or the nearest Authorized Distributor, visit automation.honeywell.com/hss or call:

USA/Canada	+302 613 4491
Latin America	+1 305 805 8188
Europe	+44 1344 238258
Japan	+81 (0) 3-6730-7152
Singapore	+65 6355 2828
Greater China	+86 4006396841

WARRANTY/REMEDY

Honeywell warrants goods of its manufacture as being free of defective materials and faulty workmanship during the applicable warranty period. Honeywell's standard product warranty applies unless agreed to otherwise by Honeywell in writing; please refer to your order acknowledgment or consult your local sales office for specific warranty details. If warranted goods are returned to Honeywell during the period of coverage, Honeywell will repair or replace, at its option, without charge those items that Honeywell, in its sole discretion, finds defective. **The foregoing is buyer's sole remedy and is in lieu of all other warranties, expressed or implied, including those of merchantability and fitness for a particular purpose. In no event shall Honeywell be liable for consequential, special, or indirect damages.**

While Honeywell may provide information or engineering support for its products through Honeywell personnel, literature and website, it is the buyer's sole responsibility to determine the suitability of the Honeywell product(s) for the buyer's requirements.

Specifications may change without notice. The information we supply is believed to be accurate and reliable as of this writing. However, Honeywell assumes no responsibility for its use.

⚠ WARNING **MISUSE OF** **DOCUMENTATION**

- The information presented in this product sheet is for reference only. Do not use this document as a product installation guide.
- Complete installation, operation, and maintenance information is provided in the instructions available for download on the [Honeywell website](https://www.honeywell.com).

Failure to comply with these instructions could result in death or serious injury.

SAFETY NOTE

This sensor is designed to be used in safety critical applications. To ensure that the sensor and/or instrument in which it is used, are operating properly, it is a requirement that the function of the device is confirmed by exposure to target gas (bump check) before each use of the sensor and/or instrument. Failure to carry out such tests may jeopardize the safety of people and property.



Honeywell Healthcare Solutions GmbH

Alter Holzhafen 18, 23966 Wismar,
Germany
Phone: +49 (0)3841-360-1
Phone: +49 (0)3841-360-200

Honeywell Sensing Solutions

830 East Arapaho Road
Richardson, TX 75081
www.honeywell.com